

alea

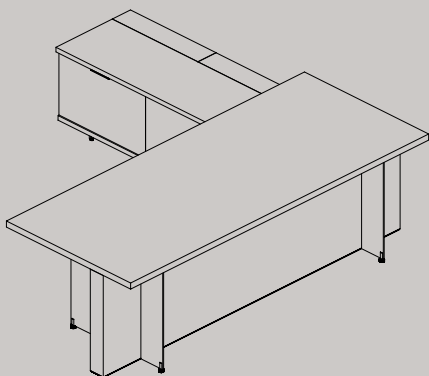

OASI

direzionali | executive | mobilier de direction | ejecutivos



ACATTA



Materiali a contrasto

Un sistema direzionale moderno che combina materiali differenti distinguendosi per il design contemporaneo

A modern executive collection with a contemporary design blanding different materials.

Un système directionnel moderne qui combine des matériaux différents en se distinguant par son design contemporain.

Un moderno sistema direccional que combina diferentes materiales destacándose por su diseño contemporáneo.

/la forma incontra la materia

Oasi è la collezione direzionale che si distingue per la sua gamba, una lama di metallo che crea nuove geometrie grazie all'incontro tra gli elementi. I dettagli esaltano la sua linea, moderna ed autorevole. I piani sono stati pensati per lasciare spazio ai contrasti. Qui il calore e la matericità del legno incontra materiali di pregio quali il cuoio, il vetro, il gres.

/meeting between shape and substance
Oasi is the executive collection that stands out for its leg, a metal blade that creates new geometries thanks to the intersection of elements. Details enhance its line, modern and distinguished. Tops are designed to allow contrasts. The warm texture of wood meets precious materials such as leather, glass and porcelain tiles.

Il la forme se mélange avec la matière
Oasi est la collection exécutive qui se différencie pour son pied, une lame en métal qui crée des nouvelles géométries avec les autres éléments. Les détails exaltent son gamme, moderne et prestigieuse. Les plateaux ont été conçus pour permettre les contrastes. Ici la finition chaleureuse du bois se mélange avec matières comme cuir, verre et gres.

Il la forma encuentra la materia *Oasi es la colección ejecutiva que se distingue por su pata, una hoja de metal que crea nuevas geometrías gracias al el encuentro entre los elementos. Los detalles exaltan su línea moderna y prestigiosa. Los sobres de las mesas, se han diseñado para dejar espacio a los contrastes. Aquí el calor y la matericidad de la madera se une a materiales preciosos como cuero, vidrio y gres.*



/design

La gamba in metallo è spessa 8 mm e viene intersecata da un modesty disponibile in due varianti: a tutta altezza, oppure rialzato di 25 cm da terra. Nel primo caso oltre alla funzione estetica, viene aggiunta quella di una completa gestione dei cavi. Nel secondo caso il cablaggio può raggiungere il piano scrivania passando all'interno di un carter rettangolare magnetico applicato a lato della gamba stessa.

/design the metal leg is 8 mm (1/4") thick and is intersected by a modesty available in two variants: at full height, or raised 25 cm (9") from the floor. The first option, in addition to the aesthetic function, offers a complete cable management. In the second option, cabling can reach the desk top through a rectangular magnetic duct applied to the leg side.



/design Le pied en métal a une épaisseur de 8 mm et il est croisé par une voile de fond disponible en deux variantes: en toute hauteur ou rehaussée de 25 cm du sol. Dans le premier cas, outre à la fonction esthétique, elle a une fonction complète pour la gestion des câbles. Dans le deuxième cas, le câblage peut arriver au plateau en passant à travers un carter rectangulaire magnétique appliqué latéralement du pied.

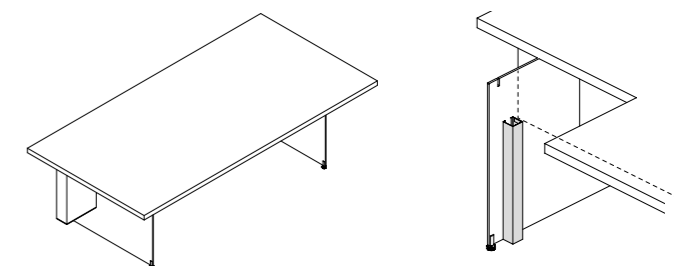

/diseño la pata metálica tiene un grosor de 8 mm y es intersectada por un faldón disponible en dos variantes: altura total o elevado a 25 cm del suelo. En el primer caso, además de la función estética se añade una gestión completa de los cables. En el segundo caso, el cableado puede llegar al sobre de la mesa pasando por el interior de un carter magnético rectangular aplicado a lado de la misma pata.

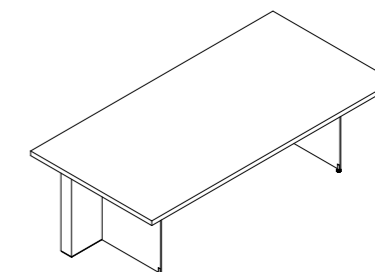





***power modules** power components are always installed near the modesty panel on every desk. More precisely, for desks with top made of two materials (wood/porcelain tiles, wood/leather, wood/glass) power modules are always placed on the wood portion.*

***l'électrification** dans tous les bureaux, les accessoires d'électrification sont toujours placés près du voile de fond. Plus précisément, dans les bureaux avec des plateaux composés de deux matériaux différents, bois/grès, bois/cuir, bois/verre, les accessoires pour l'électrification se retrouvent toujours dans la partie en bois.*

***l'electrificación** en todas las mesas, los accesorios para la electrificación siempre vienen colocados en proximidad del faldón. Y más precisamente, en las mesas con sobre que se compone por dos materiales, madera/gres, madera/cuero, madera/vidrio, los accesorios para electrificación, siempre se encuentran en la parte de madera.*



/elettificazione

In tutte le scrivanie, gli accessori per l'elettificazione vengono sempre posizionati in prossimità del modesty panel. E più precisamente, nelle scrivanie con piano composto da due materiali, legno/gres, legno/cuio, legno/vetro gli accessori per l'elettificazione, si trovano sempre nella parte lignea.

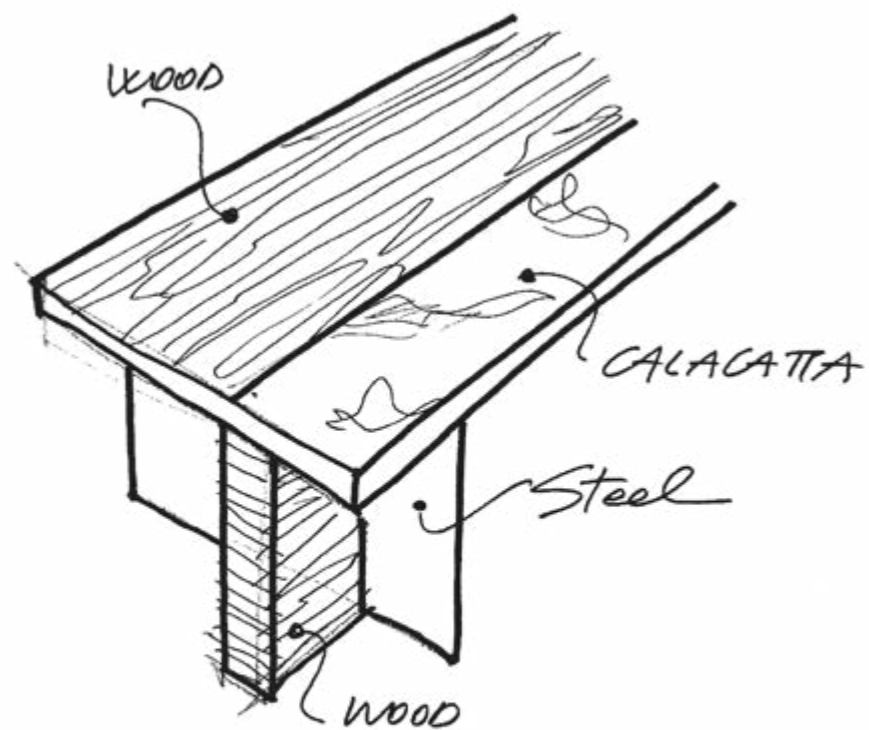



/stile

Il design di Oasi è raffinato e contemporaneo e combina comfort e funzionalità. Tutto è a portata di mano e le soluzioni per l'elettificazione del piano sono discrete ed eleganti.

I style Oasi's design is sophisticated and contemporary, providing comfort and functionality at the same time. Everything is at your fingertips and the solutions for storage and top wire management are discreet and elegant.

I style le design de Oasi est raffiné et contemporain, il allie confort et fonctionnalité. Tout est à portée de main et les solutions de rangement et pour électrifier le plateau sont discrètes et élégantes.

I estilo el diseño de Oasi es refinado y contemporáneo y combina confort y funcionalidad. Todo está a la mano y las soluciones para contención y para electrificar el sobre son discretas y elegantes.





/briefing

Al fine di fornire lo spazio a riunioni direzionali, alla scrivania, possono essere agganciati tavoli briefing 1800x900 mm e 900x800 mm sostenuti da gambe metalliche con sezione a T, verniciate a polveri epossidiche.

***I briefing** in order to provide space for executive meetings, briefing tables can be hung onto the desk. Briefing tables are available in the following dimensions, 1800x900 mm (70 7/8" x 35 7/16") and 900x800 mm, (35 7/16" x 31 1/2") and are supported by metal legs with T-section, epoxy painted.*

***I briefing** afin de fournir de l'espace lors des réunions de direction, il est possible de fixer au bureau des tables briefing 1800x900 mm et 900x800 mm, reposant sur des pieds métalliques à section en T, finition époxy.*

***I briefing** para proporcionar espacio para reuniones ejecutivas, a la mesa principal, se pueden adjuntar mesas briefing de 1800x900 mm y 900x800 mm soportadas por patas de metal con sección en en forma T, pintadas con polvos epoxi.*

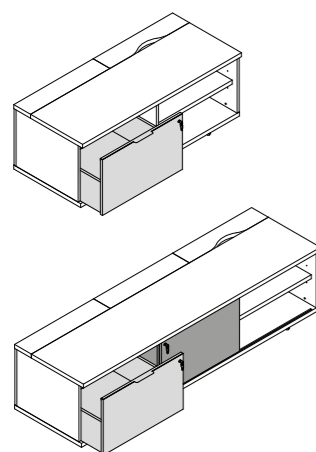

Cassetto classificatore

Filing drawer
Tiroir pour DS
Cajon archivador

Anta scorrevole

Sliding door
Porte coulissante
Puerta corrediza

The lateral storage unit is available in two sizes. The smaller one is 138 cm (54 3/8") long and consists of a filing drawer and an open compartment, while the larger version is 207 cm (81 1/2") long and has an additional third compartment, closed by a sliding door.

Le rangement latéral est disponible en deux dimensions. Le plus petit mesure 138 cm de long et se compose d'un tiroir pour DS et d'un compartiment ouvert, tandis que le plus grand mesure 207 cm de long et comporte un troisième compartiment supplémentaire, fermé par une porte coulissante.

El contenedor lateral está disponible en dos medidas. La más pequeña mide 138 cm de largo y consta de un cajón archivador y un compartimento abierto, mientras que la versión más grande mide 207 cm de largo y tiene un tercer compartimento adicional, cerrado por una puerta corredera.

/contenitore laterale

Il contenitore laterale è disponibile in due dimensioni. La più piccola è lunga 138 cm ed è composta da un cassetto classificatore ed un vano a giorno, mentre la versione più grande è lunga 207 cm ed ha un terzo vano in aggiunta, chiuso da anta scorrevole.





/luxury these pictures show a leather pad on a wood veneer desk top. The leather pad can be built-in, sliding or just laid on the desk surface. The sliding version opens to concealed small compartments framed by an aluminium edge. The bottom of each compartment has the same finish as the pad. It can be accessorised with Flat type power module, available with different configurations.

/luxe le plateau du bureau peut être enrichi d'un sous-main en cuir encastré, coulissant ou encore fixe. La version coulissante dissimule des compartiments obtenus dans l'épaisseur du top, délimités par un cadre en aluminium et dont le fond est revêtu du même cuir que le sous-main. On peut l'accessoiriser avec prise électrifiée Flat, disponibles en différentes configurations.

/lujo el sobre mesa de madera, puede estar equipado con un vade de escritura en cuero, encajado, deslizante o apoyado. La versión deslizante oculta unos módulos, obtenidos dentro del espesor del sobre, delimitados por un marco de aluminio y con el fondo revestido en cuero del mismo acabado que el vade de escritura deslizante. Se puede equipar con módulos electrificados Flat, disponibles en distintas combinaciones.

/lusso

Il piano scrivania in legno può essere dotato di sottomano in cuoio, incassato, scorrevole, o appoggiato sul piano. La versione scorrevole nasconde dei vani, ricavati entro lo spessore del piano, delimitati da un telaio in alluminio e con il fondo rivestito in cuoio della stessa finitura del sottomano scorrevole. Si può accessorizzare con moduli elettrificati Flat, disponibili in varie configurazioni.

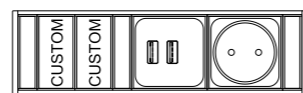
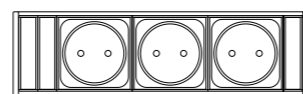





I return Oasi also includes a desk version with hanging return, whose top is supported by a 8 mm (5/16") thick metal leg with a T section, painted in epoxy finish.

I retour Oasi propose également une version de bureau avec un retour accroché, soutenu par un pied en métal à section en forme de T de 8 mm d'épaisseur, finition époxy.

I ala suspendida Oasi también incluye una versión de mesa con ala suspendida, soportada por una pata de metal de 8 mm de espesor con sección en forma de T, pintada con polvos epoxi.



/dattilo

Oasi prevede anche una versione di scrivania con dattilo agganciato, sostenuto da una gamba metallica spessore 8 mm con sezione a T, verniciata a polveri epossidiche.



I meeting The Oasi meeting tables are available with either full-height modesty panel or column bases. The first version follows the desk design and its length starts from 210 cm (82 5/8") up to over 6 metres (236").

I reunions les tables de réunion Oasi sont disponibles en version a toute hauteur et avec des pieds en colonne. La première version suit le design du bureau et a une longueur allant de 210 cm à plus de 6 mètres.

I reuniones las mesas de reunión Oasi están disponibles tanto con faldón de altura total como con bases de columna. La primera versión sigue el diseño del escritorio y tiene una longitud que va desde los 210 cm hasta más de 6 metros.



/riunioni

I tavoli riunione Oasi, sono disponibili sia con modesty a tutta altezza che con basamenti a colonna. La prima versione segue il design della scrivania ed ha una lunghezza che parte dai 210 cm fino a raggiungere dimensioni oltre i 6 metri di lunghezza.



/base Oasi also presents a second option, for square and rectangular conference tables up to a length of 280 cm (110 1/4"). The peculiarity of this version is the folding base, terminated by a metal plate. The column is hollow to allow cables passage. In order to take advantage of this function it can be enriched with specific grommets.

/base Oasi présente aussi une deuxième proposition pour les tables de réunion carrés et rectangulaires jusqu'à la longueur 280 cm. La particularité de cette version est le piètement en folding, qui termine avec une petite plaque en métal. La colonne est vide permettant le passage des cables. Afin de pouvoir utiliser cette fonction, on peut enrichir le piètement avec un passe-cables.

/base Oasi también presenta una segunda propuesta, para mesas de reunión cuadradas y rectangulares hasta una longitud de 280 cm. La peculiaridad de esta versión es la base plegable, terminada por una placa metálica. La columna es hueca para permitir el paso de los cables. Para esta función se puede mejorar con enriquecido con ojales.



/basamento

Oasi presenta anche una seconda proposta, per tavoli riunione quadrati e rettangolari fino ad una lunghezza di 280 cm. La peculiarità di questa versione è il basamento in folding, terminato da una piastra in metallo. La colonna è cava per permettere il passaggio dei cavi. Per sfruttarne questa funzione può essere arricchita da passacavi.



/conferenze

I tavoli riunione modulari possono arrivare ad una lunghezza di 630 cm per adattarsi anche alle sale conferenze. Il piano può essere sia rettangolare che sagomato.

***I conferences** modular meeting tables can reach a width of 630 cm (248") to suit conference rooms. Tops can be rectangular or barrel shaped.*

***I conférence** Les tables de réunion modulaires peuvent avoir une longueur de 630 cm, afin de pouvoir s'adapter également aux salles de conférence. Le plateau peut avoir une forme rectangulaire ainsi que façonné.*

***I conferencias** las mesas de reunión modulares pueden alcanzar una longitud de 630 cm para encajar también en las salas de conferencias. El sobre puede ser rectangular o con forma.*



I tavoli sono disponibili con modesty e piano sia in melaminico che in legno. Nel secondo caso è possibile applicare un prezioso inserto in pelle.

Tables are available with modesty and top in either melamine or wood veneer. In the latter case it is possible to apply a precious leather insert.

Les tables sont disponibles avec voile de fond et plateau soit en mélaminé que en bois. Dans le deuxième cas, il est possible d'appliquer un précieux insert en cuir.

Las mesas de conferencia están disponibles con faldón y sobre en melamina y madera. En el segundo caso es posible aplicar un precioso inserto de cuero.



/tavolini

A completare la proposta Oasi si possono aggiungere i tavolini da caffè Ciro con piano in legno o melaminico di spessore 30 mm e gamba in tubolare metallico sezione quadrata da 18 mm. Le dimensioni disponibili sono 60x60 e 120x60 cm, altezza 40 cm.



***/coffee tables** to complete Oasi proposal it is possible to add Ciro coffee tables with wooden or melamine top 30 mm (1 1/8") thick and 18 mm (3/4") square tubular metal leg. Available sizes are 60x60 (23 5/8"x 23 5/8") and 120x60 cm (47 1/4"x 23 5/8"), height 40 cm (15 3/4").*

/tables basses Des petits tables basses Ciro sont proposées dans la gamme Oasi. Elles ont un plateau bois ou mélaminé d'épaisseur 30 mm et pied tubulaire métallique section carré de 18 mm. Les dimensions disponibles sont 60x60 et 120x60 cm, hauteur 40 cm.

/mesitas de café para completar la propuesta Oasi, se pueden añadir las mesitas de café Ciro con sobre de madera o melamina de 30 mm de espesor y pata en tubular metálico de sección cuadrada de 18 mm. Las medidas disponibles son 60x60 y 120x60 cm, altura 40 cm.



/contenitori mobili

Le scrivanie sono facilmente abbinabili a mobili di servizio o cassettiere indipendenti, disponibili in diverse configurazioni, che si possono spostare agevolmente grazie alla presenza delle ruote di supporto.

***/mobile units** desks can be easily combined with freestanding service units or drawer units, available in various configurations, which can be moved easily thanks to the presence of support castors.*

***/caisson mobiles** les bureaux peuvent se coordonner facilement aux meubles de service ou caissons indépendants, disponibles en configurations différentes. Afin de simplifier leurs déplacement, ils ont la possibilité d'être équipés de roulettes de support.*

***/contenedores móviles** las mesas son fácilmente combinables con muebles laterales o bucs de cajones independientes, disponibles en diferentes configuraciones, y que se pueden mover fácilmente gracias a la presencia de ruedas de soporte.*



/credenze

seguendo il design della scrivania, anche la credenza è disponibile in due versioni. La prima è rialzata di 25 cm ed ha una scocca composta da quattro vani dotati di anta battente, sorretta da gambe in metallo verniciato spesse 8 mm e da un longherone strutturale.

***I credenzas** matching the desk design, credenzas are also available in two versions. The first one is raised by 25 cm (9 7/8") and has a body composed of four compartments with hinged doors, supported by 8 mm (1/4") thick painted metal legs and a structural bar.*

***I buffets** selon le design du bureau, aussi le buffet est disponible en deux versions. La première est rehaussée de 25 cm et elle a un corp composé par 4 compartiments dotés d'une porte battente. Elle est soutenu par des pieds en métal vernis avec épaisseur de 8 mm et par une poutre structurelle.*

***I credenzas** siguiendo el diseño de la mesa, la credenza también está disponible en dos versiones. La primera es elevada de 25 cm del suelo y lleva una estructura compuesta por cuatro módulos equipados con puerta abatible, y está soportada por patas metálicas pintadas de 8 mm de espesor y por un travesaño.*





La seconda tipologia di credenza presenta invece due ante battenti laterali con maniglia integrata e un vano a giorno centrale con ripiano in vetro fumè. La scocca è composta da 3 vani da 700 mm, realizzata da pannelli spessi 18 mm ed è sorretta da gambe in metallo verniciato spesse 8 mm. I folding presenti a lato delle gambe consentono il transito verticale dei cavi. Frontalmente è previsto uno zoccolo di finitura in metallo.

The second type of credenza has two lateral hinged doors with integrated handles and a central open compartment with a glass shelf, smoked finishing. The body consists of three 70 cm (27 1/2") compartments made of 18 mm (3/4") thick panels and is supported by 8 mm (1/4") thick painted metal legs. Folding ends allow vertical cable transit. A metal finishing plinth is provided at the front.

Le second type de buffet, dispose de deux portes battantes latérales avec poignée intégrée et un compartiment central ouvert est doté d'une étagère en verre fumé. La coque se compose de 3 compartiments de 700 mm, elle est réalisée avec panneaux de 18 mm d'épaisseur et soutenue par des pieds en métal peint de 8 mm d'épaisseur. Les montants latéraux en multipli de bois permettent le passage vertical des câbles. En partie frontale un socle en métal finition époxy complète la structure.

El segundo modelo de credenza tiene dos puertas laterales batientes con tirador integrado, y un módulo abierto central con estante de vidrio gris (fumé). La estructura está compuesta por 3 módulos de 700 mm, realizada con paneles de 18 mm de espesor y está soportada por patas de metal pintado de 8 mm de espesor. Los paneles "folding" que se encuentran a lado de las patas, permiten el tránsito vertical de los cables. En la parte frontal está previsto un zócalo de acabado en metal.





Il contenitore laterale può avere due o tre vani attrezzati con coperchio apribile per il passaggio dei cavi e l'accesso al vano tecnico. Inoltre i cavi possono passare da un vano all'altro, ed uscire dal fianco attraverso un passacavi.



Lateral storage unit is available with two or three compartments and a removable lid. Cables run through the back from one compartment to another and reach the desk via a lid placed on the side of the storage.

Le rangement latéral est disponible dans les versions à deux ou trois compartiments. Les câbles peuvent passer d'un compartiment à l'autre et sortir du conteneur par l'intermédiaire d'un passe câble placé sur le flanc et d'un couvercle s'ouvrant permettant également d'accéder au compartiment technique.

El contenedor lateral, está disponible en las versiones con dos o tres módulos equipados con tapa que se puede abrir para el pasaje de los cables y el acceso al módulo técnico. Los cables pueden ir de un módulo a otro, y pueden salir del costado a través de un pasacables.

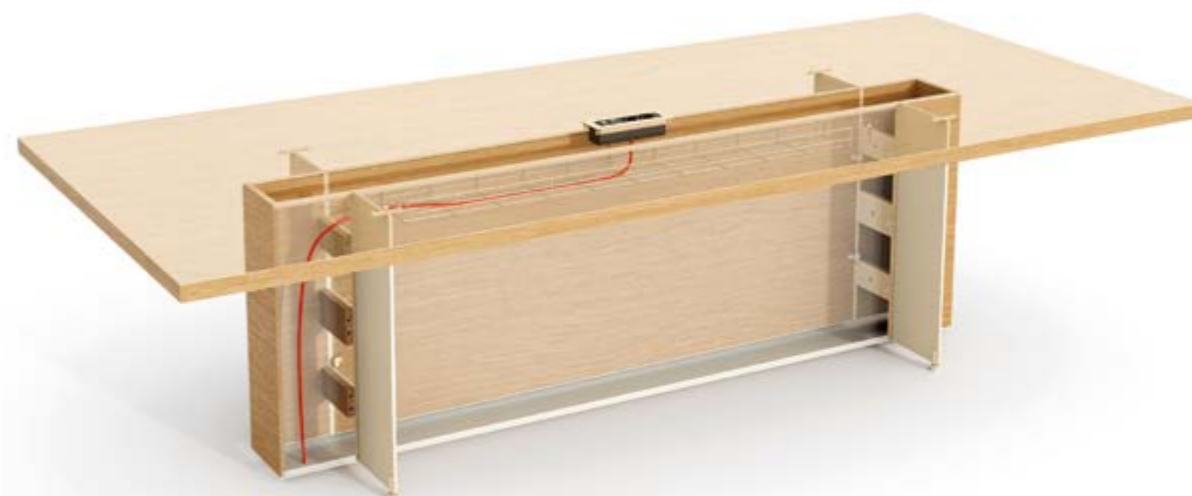

I due modesty sono progettati per consentire una gestione dei cavi facile e ordinata. Un pannello è fisso e strutturale, l'altro è rimovibile. Quest'ultimo consente l'accesso a un cestello metallico orizzontale utilizzato per far passare i cavi.



The two modesties are designed to allow easy and tidy cable management. One panel is fixed and structural, the other one is removable. The latter allows access to an horizontal metal basket used to run the cables.

Les deux voiles de fond sont étudiés pour permettre une gestion du câblage facile et ordonnée. Un panneau est fixe et l'autre amovible. Ce dernier permet l'accès à un panier en fil d'acier horizontal utilisé pour le passage de câbles.

Las dos faldones están diseñados para permitir una gestión de cables fácil y ordenada. Un panel es fijo y estructural, el otro es removible. Este último permite el acceso a una cesta metálica horizontal utilizada para pasar los cables.



Melaminico senza (A) e con (B) profilo*
 Italian melamine without (A) and with (B) profile*
 Mélamine sans (A) et avec (B) profil*
 Melaminico sin (A) y con (B) perfil*



Legno senza (C) e con (D) profilo*
 Wood veneer without (C) and with (D) profile*
 Bois sans profilé (C) et avec profilé (D)*
 Madera sin (C) y con (D) perfil*

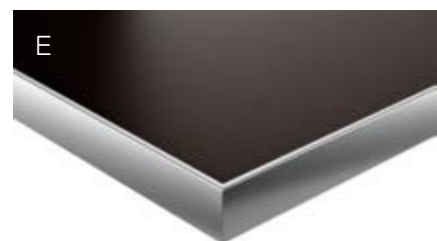

Cuoio (E), vetro (F) e gres (G) con profilo*
 Leather (E), glass (F) and porcelain tiles (G) with profile*
 Cuir (E), verre (F) et grès (G) avec profil*
 Cuero (E), vidrio (F) y gres porcelánico (G) con perfil*

***Il profilo metallico del piano può avere le seguenti finiture: anodizzato, brill, epossidico**

*The metal profile of the table top, can have the following finishes: anodised, brill, epoxy
 *Le profil métallique du dessus peut avoir les finitions suivantes: anodisé, brillant, époxy
 *El perfil metálico del sobre puede ser anodizado, brillante, pintado epoxy

Piani con doppio materiale | double material tops | plateaux avec deux matériaux | sobres con doble material

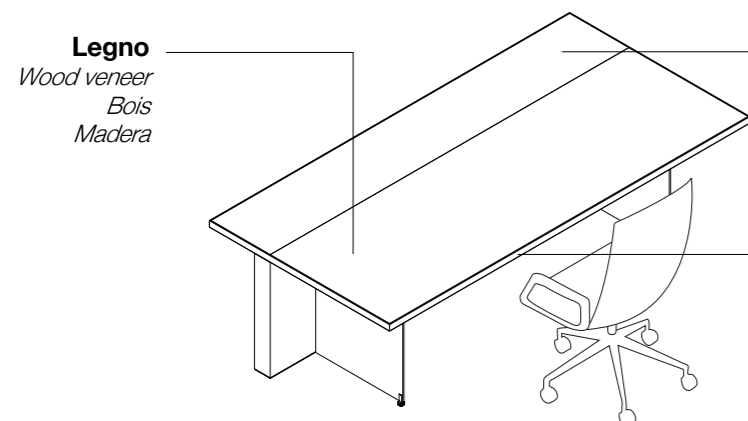

Legno
 Wood veneer
 Bois
 Madera

Cuoio, vetro o gres
 Leather, glass or porcelain tiles
 Cuir, verre ou grès
 Cuero, vidrio o gres porcelánico

Profilo metallo
 Metal profile
 Profil en métal
 Perfil metálico



In appoggio | laid | encore fixe | apoyado

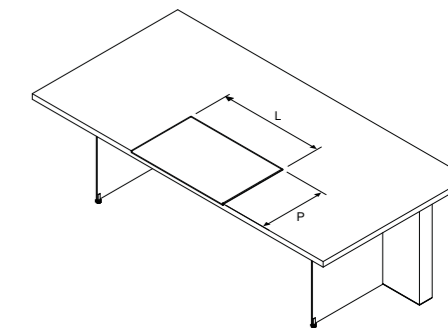

L 610 mm - P 495 mm | L 24" - P 19 8/16"
L 760 mm - P 495 mm | L 29 15/16" - P 19 8/16"
L 1010 mm - P 495 mm | L 39 12/16" - P 19 8/16"

! Su piani in melaminico e legno | on Italian melamine and wood veneer tops | pour plateaux en mélaminé et bois | sobre de melamina y madera



Incassato | built-in | encastré | encajado

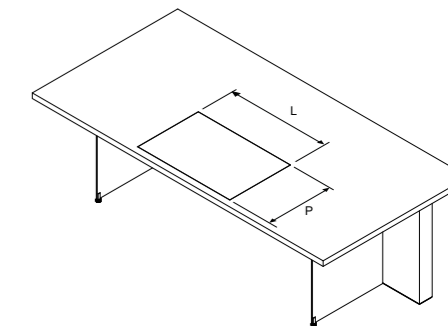

L 800 mm - P 420 mm | L 31 8/16" - P 16 9/16"

! Solo su piani in legno | on wood veneer tops only | seulement sur plateaux de bois | sólo en sobres de madera



Scorrevole | sliding | coulissant | deslizando

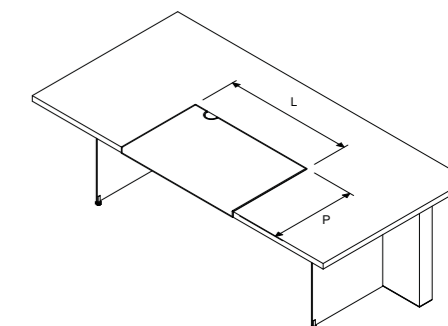

L 921 mm - P 612 mm | L 36 4/16" - P 24 1/16"

! Solo su piani in legno | on wood veneer tops only | seulement sur plateaux de bois | sólo en sobres de madera

Piani | desk tops | plateaux | sobres

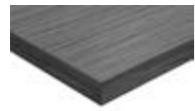

senza profilo - legno/melaminico
without profile - wood veneer/Italian melamine
sans profil - bois/méla miné
sin perfil - madera/melaminico

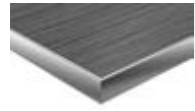

con profilo - legno/melaminico/cuoio/vetro/gres
with profile - wood veneer/Italian melamine/leather/glass/porcelain tiles
avec profil - bois/méla miné/cuir/verre/grès cérame
con perfil - madera/melaminico/cuero/vidrio/gres porcelánico

Struttura | structure | structure | estructura

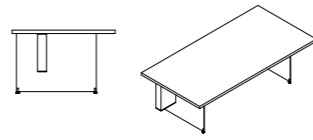

modesy a tutta altezza
full-height modesty panel
voile de fond toute hauteur
faldón altura total

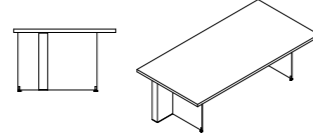

modesty rialzato di 250 mm
250 mm raised modesty panel
voile de fond relevé de 250 mm
faldón elevado de 250 mm

Gambe e profilo in metallo verniciato epossidico. Profilo disponibile anche in alluminio anodizzato o brillantato. Modesty in legno o melaminico.
Metal legs and desktop profile with epoxy finish. Profile available also in aluminium with anodized or brill finish. Wood veneer or Italian melamine modesty panel.
Pieds et profil en métal peint époxy. Profilé également disponible en aluminium anodisé ou brill. Voile de fond en bois ou méla miné.
Patas y perfil de metal pintado epoxi. Perfil también disponible de aluminio anodizado o brill. Faldón de madera o melaminico.

Scrivanie | desks | bureaux | mesas

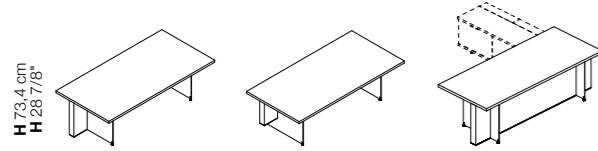

L 200/220/240 - P 100/120 cm
W 78 3/4"/ 86 5/8"/94 1/2" - D 39 3/8"/47 1/4"

Dattilo/briefing | return/briefing | retour/briefing | ala/briefing

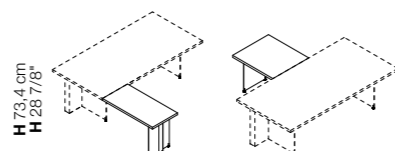

L 120 - P 60 cm
W 47 1/4" - D 23 5/8"
L 90/180 - P 80/90 cm
W 35 3/8"/70 7/8" - D 31 1/2"/35 3/8"

Tavoli riunione | meeting tables | tables de réunion | mesas de juntas

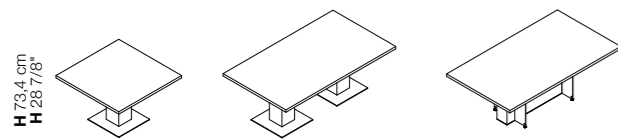

L/P 120 cm
W/D 47 1/4"
L 210/280 - P 120 cm
W 82 5/8"/110 1/4" - D 47 1/4"
L 210/280 P 120 cm
W 82 5/8"/110 1/4" - D 47 1/4"

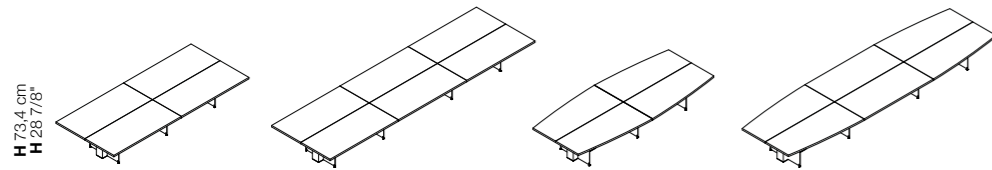

L 420 - P 180 cm
W 165 3/8" - D 70 7/8"
L 490/560/630 - P 180 cm
W 192 7/8"/220 1/2"/248" - D 70 7/8"
L 420 - P 180 cm
W 165 3/8" - D 70 7/8"
L 490/560/630 - P 180 cm
W 192 7/8"/220 1/2"/248" - D 70 7/8"

Mobili di servizio | service units | meuble retour | muebles de servicio

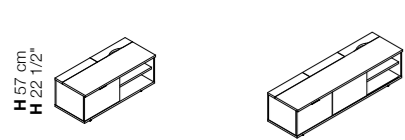

L 138 - P 60 cm
W 54 3/8" - D 23 5/8"
L 207 - P 60 cm
W 81 1/2" - D 23 5/8"

Credenze | credenzas | buffets | muebles

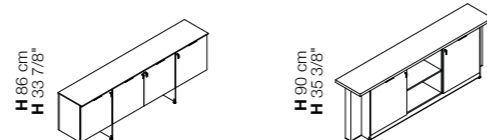

L 242 - P 45,5 cm
W 95 1/4" - D 17 7/8"
L 254 - P 47,5 cm
W 100" - D 18 3/4"











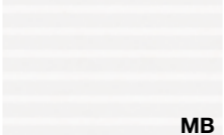



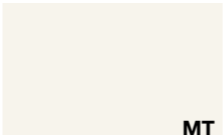

Finiture | Finishes | Finitions | Acabados

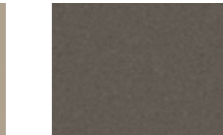
MEL

Melaminico

Melamine | Méla miné | Melaminico

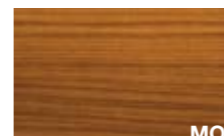

 MB	 MG	 MF	 MZ	 MN
Bianco rigato Rippled effect white Blanc avec rayures en sérigraphie Blanco rayado	Grigio rigato Rippled effect grey Gris avec rayures en sérigraphie Gris rayado	Nichel Nickel Nickel Níquel	Cacao Cocoa Cacao Cacao	Bianco White Blanc Blanco
 MT	 MJ	 MK	 MI	 MD
Talco Talco Talco Talco	Ocre Ochre Ocre Ocre	Safari Safari Safari Safari	Noisette Noisette Noisette Noisette	Ardesia Ardesia Ardesia Pizarra
 ML	 MQ	 MC	 MY	 ME
Nero Black Noir Negro	Blu notte Night blue Bleu nuit Azul noche	Rovere chiaro Light oak Chêne clair Roble claro	Rovere americano American oak Chêne américain Roble americano	Rovere grigio Grey oak Chêne gris Roble gris
 MM	 MO	 MW		
Rovere moro Dark oak Chêne foncé Roble oscuro	Noce Canaletto Canaletto Walnut Noyer Canaletto Nogal Canaletto	Noce scuro Dark walnut Noyer foncé Nogal oscuro		

LGN

Legno

Wood | Bois | Madera



Rovere chiaro
Light oak
Chêne clair
Roble claro



Rovere grigio fumo
Smoke grey oak
Chêne gris de fumée
Roble gris humo



Rovere moro
Dark oak
Chêne foncé
Roble oscuro



Noce Canaletto
Canaletto walnut
Noyer Canaletto
Nogal Canaletto



Ebano silver
Silver ebony
Ebony silver
Ebano plata



Ebano Makassar
Makassar ebony
Ebony Makassar
Ebano Makassar



Noce termocotto
Heat-treated walnut
Noyer thermo traité
Nogal termotratado

TOP MOB MOD

VTR

Vetro (anche antimpronta NFG)

Glass (also antifinger NFG) | Verre (également antitaches) | Vidrio (también anti-huella)



Bianco
White
Blanc
Blanco



Argento
Silver
Argent
Plata



Grigio scuro
Dark grey
Gris foncé
Gris oscuro



Noisette
Noisette
Noisette
Noisette

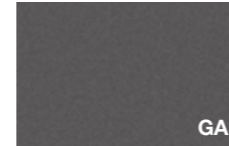

Ardesia
Ardesia
Ardesia
Pizarra

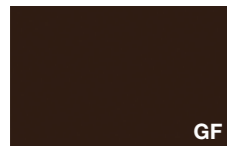

Moka
Mocha
Moka
Café

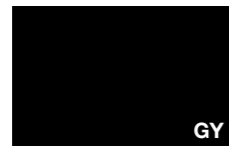

Nero
Black
Noir
Negro



Arancione
Orange
Orange
Naranja



Rosso "F"
Red "F"
Rouge "F"
Rojo "F"



Rubino
Ruby
Rubis
Rubi



Indaco
Indigo
Indigo
Azul Indigo



Azzurro
Blue
Bleu
Azul



Verde
Green
Vert
Verde



Cedro
Lime green
Vert Cédrat
Verde Cedro

TOP

CUO

Cuoio

Leather | Cuir | Cuero



Bianco
White
Blanc
Blanco



Alluminio
Aluminium
Aluminium
Aluminio



Nero
Black
Noir
Negro



Testa di moro
Brown
Tête de maure
Marron oscuro



Caramello
Caramel
Caramel
Caramelo



Arancione
Orange
Orange
Naranja

TOP

GRES

Gres porcellanato

Porcelain tiles | Grès cérame | Gres porcelánico



Nero
Black
Noir
Negro



Basalt
Basalt
Basalt
Basalt



Calacatta
Calacatta
Calacatta
Calacatta



Pulpis
Pulpis
Pulpis
Pulpis



Corten
Corten
Corten
Corten

TOP

EPX

Epossidico

Epoxy | Époxy | Epoxi



Bianco
White
Blanc
Blanco

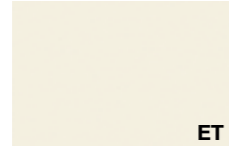

Talco
Talco
Talco
Talco



Grigio
Grey
Gris
Gris



Beige Arizona
Arizona beige
Beige Arizona
Beige Arizona



Noisette
Noisette
Noisette
Noisette

PR

STRU



Safari
Safari
Safari
Safari



Rame
Copper
Cuivre
Cobre



Rosso Jaipur
Jaipur red
Rouge Jaipur
Rojo Jaipur



Bronzo
Bronze
Bronze
Bronze



Blu notte
Night blue
Bleu nuit
Azul noche



Grigio Bromo
Bromo grey
Gris Bromo
Gris Bromo

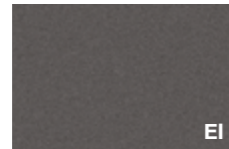

Ardesia
Ardesia
Ardesia
Pizarra



Verde Comodoro
Comodoro green
Vert Comodoro
Verde Comodoro



Nero
Black
Noir
Negro

CRM

Acciaio inox

Stainless steel | Acier inoxydable | Acero inoxidable



Lucido
Polished
Poli
Pulido

STRU

BR

Alluminio

Aluminium | Aluminium | Aluminio



Brill
Brill
Brill
Brill

PR

Applicazioni finiture

Finish application | Application finitions | Aplicacion acabados

TOP

Piano
Top
Plateau
Sobre

MOD

Modesty panel
Modesty panel
Voile de fond
Faldón

MOB

Mobile di servizio
Service unit
Meuble de service
Mueble de servicio

STRU

Struttura
Structure
Structure
Structura

PR

Profilo scrivania
Top edge
Chant plateau
Perfil sobre de mesa

Ambiente e sicurezza | Environment and safety | Environnement et sécurité | Medio ambiente y seguridad

Alea utilizza per i suoi prodotti e i suoi imballi materiali facilmente separabili e riciclabili.

Nella produzione dei suoi manufatti, Alea si impegna ad utilizzare materiali legnosi FSC e pannelli a base di legno con certificazione CARB2. I pannelli CARB2 presentano un rilascio di formaldeide inferiore rispetto al pannello E1 comunemente utilizzato (classe E1 secondo il DM 10/10/2008).

Alea uses materials that are easy to separate and recycle for its products and packaging.

Alea is committed to using FSC wood-based materials and CARB2-certified wood-based panels.

CARB2 panels have a lower formaldehyde release than the commonly used E1 panel (class E1 according to DM 10/10/2008).

Alea utilise des matériaux facilement séparables et recyclables pour ses produits et ses emballages.

Dans la production de ses produits, Alea s'engage à utiliser des matériaux en bois FSC et des panneaux à base de bois avec la certification CARB2. Les panneaux CARB2 dégagent moins de formaldéhyde que le panneau E1 couramment utilisé (classe E1 selon DM 10/10/2008).

Para sus productos y embalajes, Alea utiliza materiales fácilmente separables y reciclables.

En la fabricación de sus productos, Alea se compromete a utilizar materiales de madera FSC y paneles de madera con certificación CARB2. Los paneles CARB2 tienen una menor liberación de formaldehído que el panel E1 comúnmente utilizado (clase E1 según DM 10/10/2008).

concept & graphic design

Alea marketing + communication

design

Mirto Antonel & Filippon

art direction

Mirto Antonel

AD/CAGB/AC



GLOBAL HEADQUARTERS AND SHOWROOM : Via Col de Rust, 19 - 33070 Sarone (PN) - Italia : Tel ++39 0434 777 333
email: info@aleaoffice.com **PARIS SHOWROOM** : 176 Avenue Charles de Gaulle 92200, Neuilly-sur-Seine - France **NORTH AMERICAN**
HEADQUARTERS : Midtown 2, 3449 NE 1st Avenue L-32, Miami, FL 33137 - USA : Tel ++1 305 470 1200 - email: info@alea-usa.com
ALEA UK OFFICE AND SHOWROOM : 50-54 Clerkenwell Road, London EC1M 5PS - email: info@aleaoffice.com