

alea

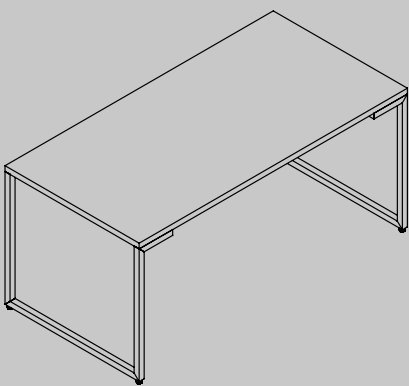

IBIS

---

operativi | workstations | systemes | operativos

# why ibis

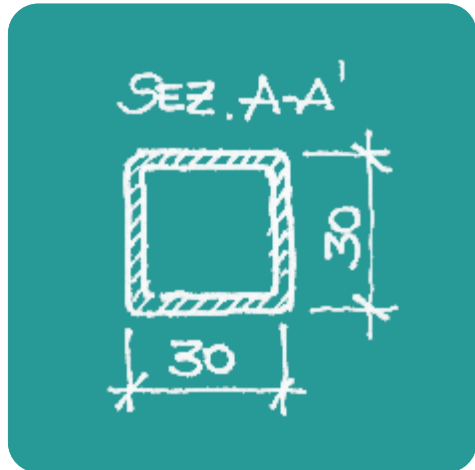
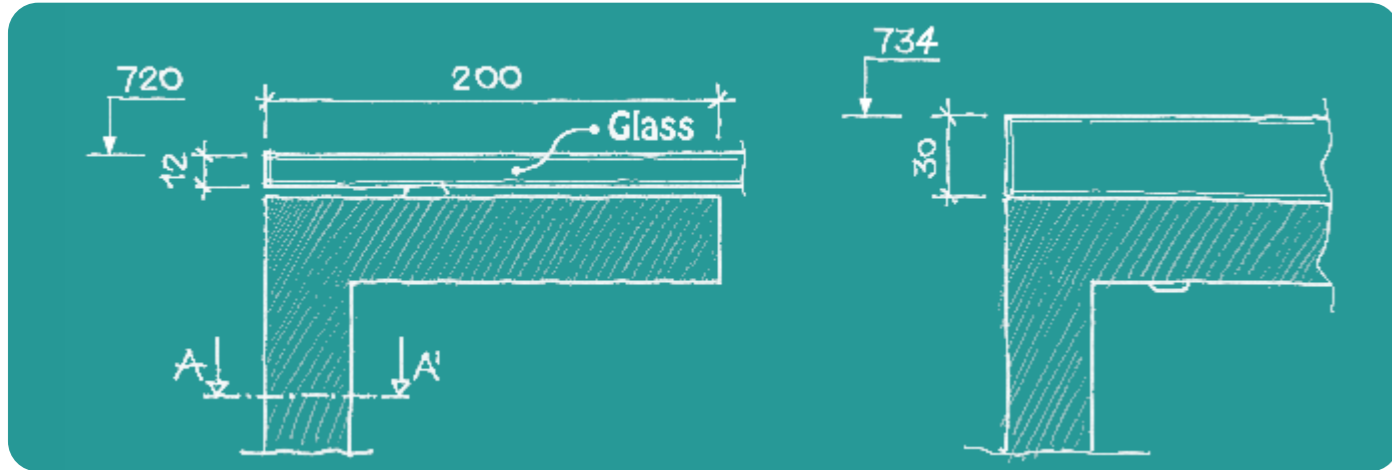

wiring

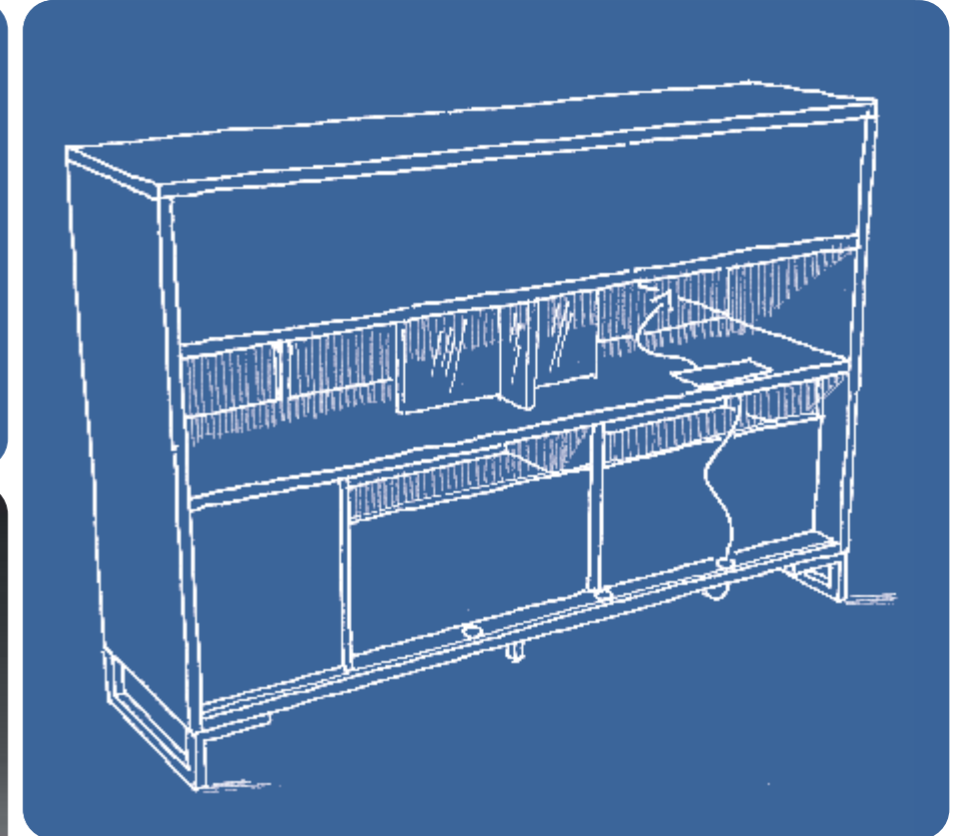

geometry

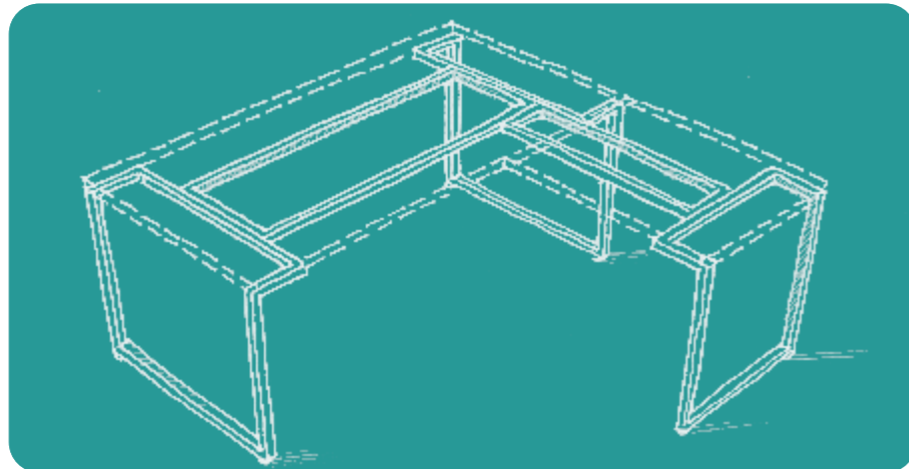

# why ibis

screen

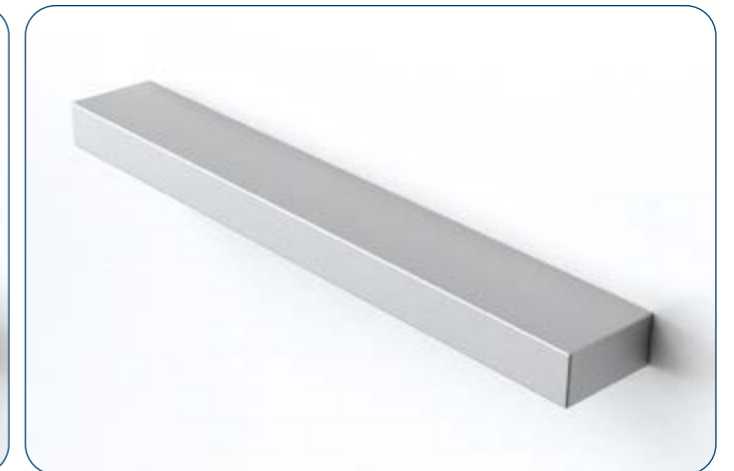
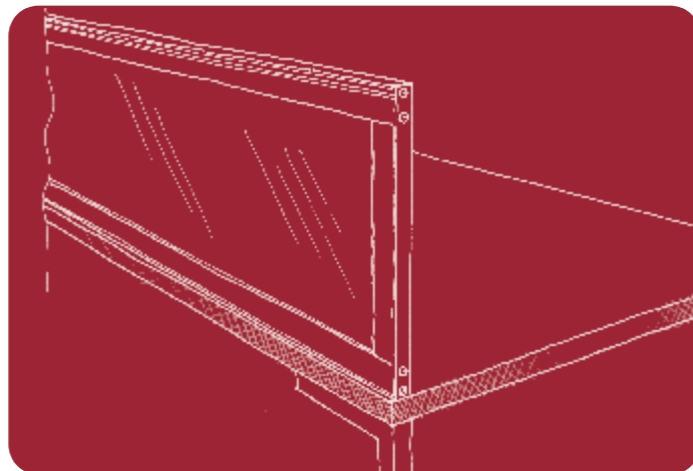
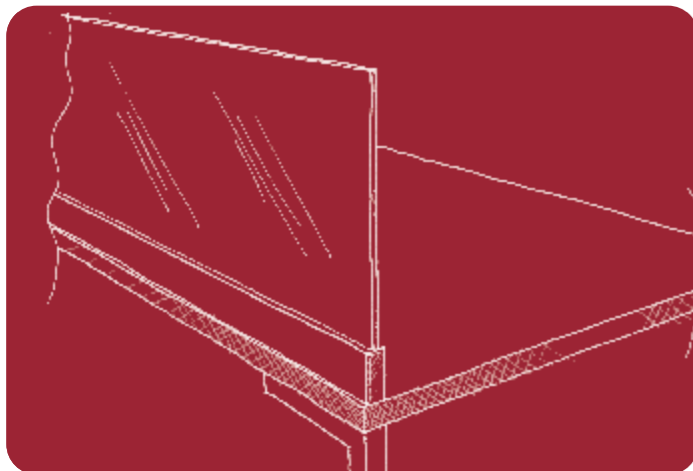
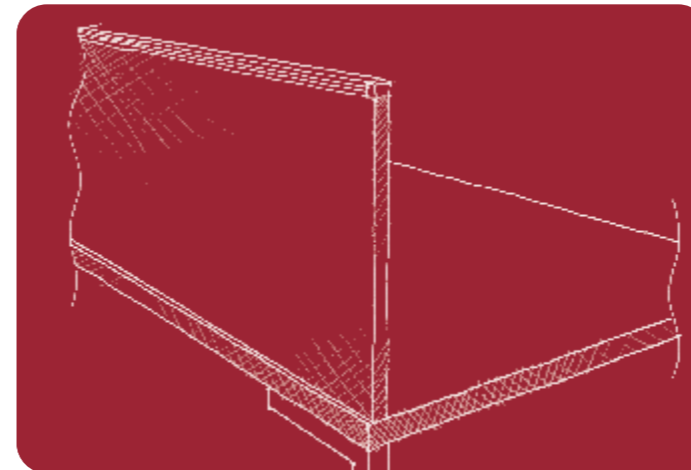
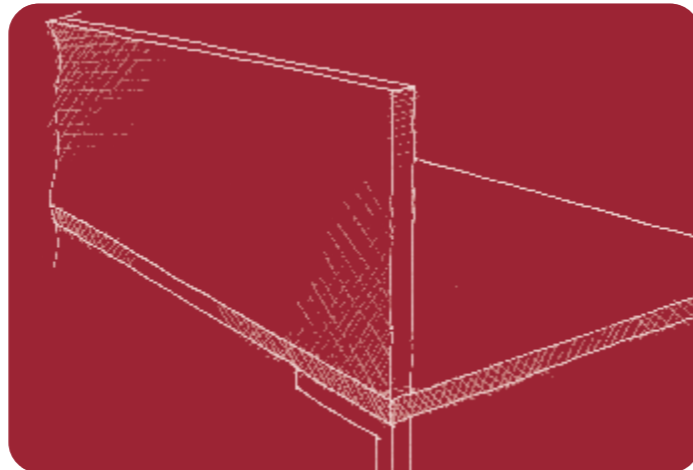
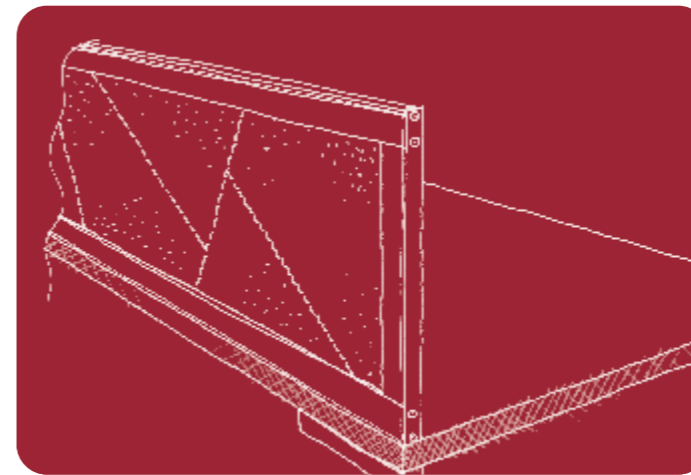

handles





IBIS est la nouvelle collection conçue par Mirto Antonel pour Alea Office. Réalisée pour un environnement de travail fonctionnel et moderne, la collection Ibis prévoit autant des bureaux individuels que des postes multiples. Le délicat travail de pliage du piétement à section carrée - 30 mm - lui confère un design pur et élégant.

IBIS es la nueva colección diseñada por Mirto Antonel para Alea Office. Pensada para un moderno ambiente de trabajo y espacio de trabajo funcional, Ibis incluye tanto las configuraciones conjuntas como individuales. Su diseño se caracteriza por la pata de anillo plegado hacia el interior, realizada con un perfil de acero de sección cuadrada de 30mm.



**IBIS è la nuova collezione disegnata da Mirto Antonel per Alea Office. Pensato per un moderno ambiente di lavoro e spazi di lavoro funzionali, IBIS comprende sia le postazioni aggregate che quelle individuali. Il suo design è caratterizzato dalle gambe ad anello piegate verso l'interno, realizzate con un profilo in metallo a sezione quadrata di 30 mm.**

IBIS is the new collection designed by Mirto Antonel for Alea Office. Designed for modern and functional workspaces, Ibis includes both multiple and individual workstations. Its design features ring legs folded towards the inside manufactured from 3 mm thick steel square section.







**La struttura portante di IBIS è leggera ed elegante. La gamba è stata pensata per integrarsi visivamente col piano scrivania di cui condivide lo spessore. Tra le caratteristiche architettoniche peculiari di IBIS troviamo le grandi superfici di lavoro singole e doppie che vanno a coprire le cassettiere strutturali, disponibili in diverse larghezze.**

IBIS' bearing structure is light and elegant. The leg has been thought to visually integrate with the desk top whose profile it shares. Among Ibis' architectural features are large single or double worksurfaces that cover the structural pedestals, which are available in different widths.

La structure porteuse de IBIS est légère et élégante. Le pied a été étudié pour s'intégrer visuellement au plan de travail et pour s'adapter à toute solution d'implantation. Ce que vous offre Ibis, c'est la possibilité de proposer de grandes surfaces de travail, en postes simples ou doubles, qui peuvent couvrir même les caissons porteurs, ces derniers disponibles en plusieurs largeurs.

La estructura de IBIS es ligera y elegante. La pata está pensada para integrarse visualmente con el tablero de la mesa con el que comparte el espesor. Entre las características arquitectónicas peculiares de Ibis encontramos las grandes superficies de trabajo individual y doble que van a cubrir las cómodas estructuras, disponibles en diferentes longitudes.







**Le cassettiere sono dotate di un retro vano che consente il transito verticale dei cavi e la fuoriuscita sul piano lavoro tramite top access. Gli screen sono disponibili in diversi materiali (tessuto con o senza telaio metallico, metacrilato con telaio metallico o cornice in alluminio, melaminico) e vengono fissati direttamente sopra il piano lavoro sia esso singolo o doppio.**

Pedestals are equipped with a hollow backspace that allows vertical cables transit and thanks to the top access they exit on to the worktop. Screens are available in several materials (fabric with or without metal frame, acrylic with metal or aluminium frame, Italian melamine) and they are fixed directly over the worksurface single or double.

Les caissons intègrent un creux technique qui permet le logement ainsi que gestion efficace des fluides, d'où ils peuvent facilement remonter et sortir sur le plan de travail parmi le top access. Les écrans, fixés directement sur le plan de travail simple ou double, sont proposés dans différents matériaux: tissu sans ou avec cadre métallique (permettant l'accrochage des accessoires), métacrylate avec profil inférieur ou cadre métallique (ce dernier permettant l'accrochage des accessoires), mélaminé avec profil supérieur (permettant l'accrochage des accessoires).

Las cajoneras estan equipadas en su parte trasera con un compartimento que permite el paso vertical del cableado y la subida ala superficie a traves de una tapa abatible/top access en la encimera. Las pantallas divisorias estan disponibles en diversos materiales (tejido con o sin marco metálico, metacrilato con marco metálico o de aluminio, melamina) y son fijadas directamente sobre el plano de trabajo, sea individual o doble.





**Un altro dettaglio unico nel design di IBIS è il contenitore laterale a giorno sospeso. Viene solidamente agganciato alla struttura del bench ed offre uno spazio contenitivo comodo e accessibile agli operatori.**

Another unique detail for IBIS' design is the open lateral storage unit. It is firmly hung to the bench structure and offers a convenient storage space easy to access for the users.

Un autre détail propre au design de IBIS, c'est le rangement filaire ouvert fixé sur le côté latéral du poste de travail.

En plus de son aspect esthétique agréable, il offre une solution fiable d'un espace de rangement complémentaire et facilement accessible.

Otro detalle único del diseño de IBIS es el contenedor lateral suspendido. Viene sólidamente sujeto a la estructura del bench y ofrece un espacio de almacenaje cómodo y accesible a los usuarios.













**IBIS propone una versione di gamba centrale a croce per i tavoli riunione rotondi o quelli rettangolari. Questi ultimi sono disponibili sia in melaminico che rivestiti in pelle con cuciture a vista.**

IBIS introduces a different version of the central crossed-shaped leg used for either rounded or rectangular conference and meeting tables. They are available in Italian melamine or covered in leather with stitches in view.

IBIS propose une version de pied central en croix pour les tables de réunion rondes ou rectangulaires. Ces dernières sont disponibles en mélamine ainsi qu'en cuir avec coutures apparentes.

IBIS propone una versión de pata central en cruz para las mesas de reunión redondas o rectangulares. Estas últimas están disponibles tanto en tablero melaminico como revestido en cuero con costuras a la vista.



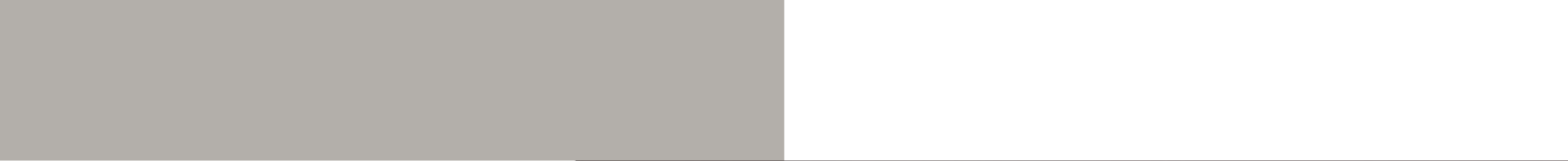

Una particolare versione di tavolo direzionale IBIS prevede l'utilizzo di piani completamente trasparenti che lasciano a vista la struttura portante sottostante. Le molte tinte epossidiche a disposizione consentono molte combinazioni di colore con le cassettiere e i contenitori.



IBIS executive desk collection offers an option that features the use of completely transparent glass table tops that leaves the underlying bearing structure visible. The several epoxy finishes available allow many colour combinations with the pedestals and storage units.

Une version particulière du bureau de direction IBIS prévoit l'utilisation d'un plan de travail complètement transparent avec un plateau en verre permettant de profiter de la magnifique structure portante. De nombreuses teintes de peinture époxy vous permettent de multiples combinaisons pour personnaliser vos environnements de travail.

Una particular versión de mesa de imagen direccional IBIS ofrece el uso de sobres de mesa completamente transparentes que dejan expuesta a la vista la estructura de soporte de la mesa. La amplia gama de colores de pintura epoxy disponibles permite muchas combinaciones de color con las cajoneras y los contenedores

**Il sistema IBIS prevede contenitori laterali strutturali dotati di vani superiori chiusi con ante scorrevoli e vani inferiori per il contenimento di cassettiere e filer. Sono disponibili due versioni: una con piedini regolabili ed una seconda con supporto metallico per rialzare il fondo del contenitore e ospitare il transito orizzontale dei cavi.**



IBIS system features side storage units equipped with sliding doors overhead cabinets and lower cabinets to contain drawers and filers. They can be specified in two versions: one with height adjustable feet the other with metal support to raise the base of the storage unit and carry the horizontal cables.

Le système IBIS prévoit des rangements latéraux composés avec compartiments supérieurs fermés par des portes coulissantes et des compartiments inférieurs qui peuvent être à jour ou bien équipés avec blocs tiroirs et niche support UC. Deux versions sont disponibles: la première, plus simple, équipée avec des vérins de réglage pour la mise à niveau au sol et la seconde, plus technique, dotée d'un support métallique qui permet de relever le meuble et laisser ainsi un espace pour le passage horizontal des câbles.

El sistema IBIS dispone de armarios contenedores laterales estructurales con compartimentos superiores cerrados con puertas correderas y compartimentos inferiores para integrar los cajones y archivadores. Existen dos versiones: una con pies ajustables y una segunda con un soporte metálico para elevar el fondo del contenedor y permitir el paso horizontal de los cables.



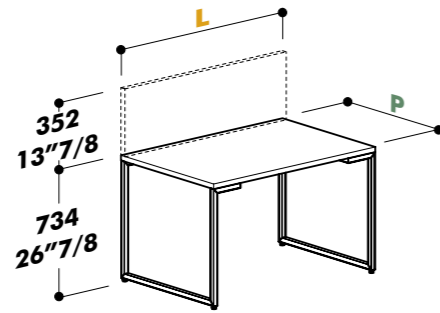

**Scrivania** desk/bureau/mesa

L						P					
1200	47"1/4	1400	55"1/4	1600	63"	1800	70"7/8	2000	78"3/4	800	31"1/2
						1800	70"7/8	2000	78"3/4	900	35"7/16

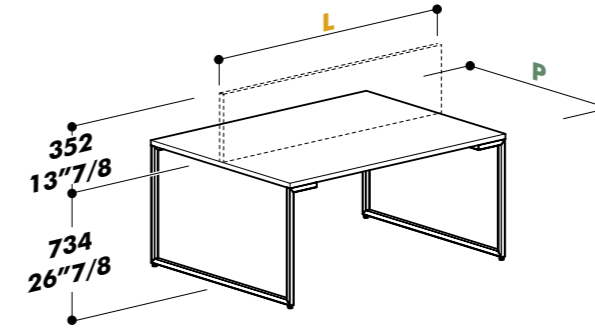

**Bench 2p.** bench 2p./bench 2p./bench 2p.

L						P					
1200	47"1/4	1400	55"1/4	1600	63"	1800	70"7/8	2000	78"3/4	1200	47"1/4
1200	47"1/4	1400	55"1/4	1600	63"	1800	70"7/8	2000	78"3/4	1600	63"

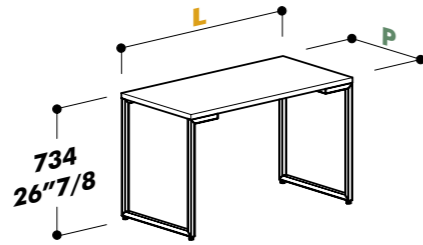

**Dattilo indipendente** freestanding return/retour indépendant/ala independiente

L				P			
800	31"1/2	1000	39"3/8	1200	47"1/4	600	23"5/8

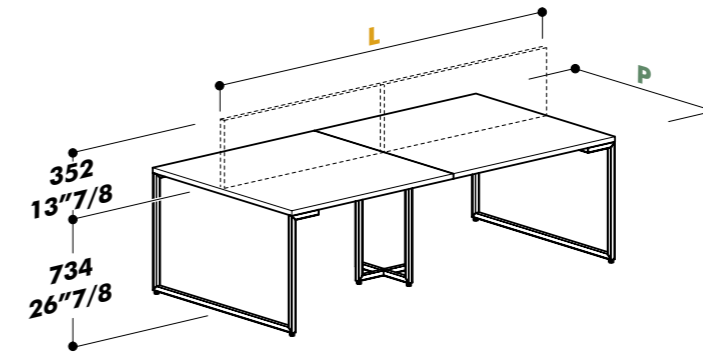

**Bench 4p.** bench 4p./bench 4p./bench 4p.

L						P					
2400	94"1/2	2800	110"1/4	3200	126"	3600	141"3/4	4000	157"1/2	1200	47"1/4
2400	94"1/2	2800	110"1/4	3200	126"	3600	141"3/4	4000	157"1/2	1600	63"

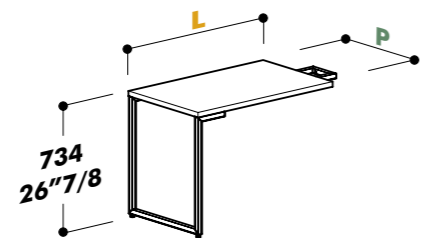

**Dattilo agganciato** hanging return/retour accroché/ala suspendida

L				P			
800	31"1/2	1000	39"3/8	1200	47"1/4	600	23"5/8

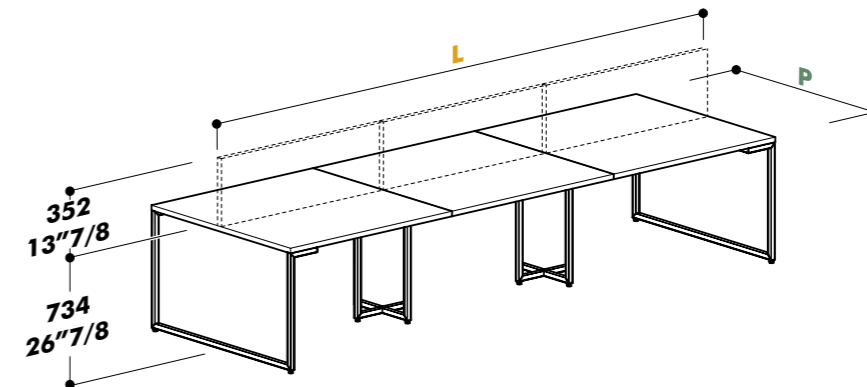

**Bench 6p.** bench 6p./bench 6p./bench 6p.

L						P					
3600	141"3/4	4200	165"3/8	4800	189"	5400	212"5/8	6000	236"1/4	1200	47"1/4
3600	141"3/4	4200	165"3/8	4800	189"	5400	212"5/8	6000	236"1/4	1600	63"

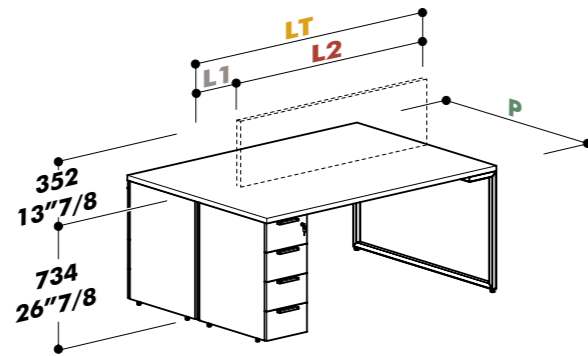

**Bench 2p. con cass.** bench 2 p. with pedestal/bench 2p. avec caisson/ bench 2 p. con buc

LT = L1 + L2		L1							P	
		300	416	700	800	900				
L2	1200	11"13/16	16"3/8	27"9/16	31"1/2	35"7/16			1200	47"1/4
	1400	59"1/16	63"5/8	74"13/16	78"3/4	82"11/16			1600	63"
	1600	66"15/16	71"1/2	82"11/16	86"5/8	90"9/16				
	1800	74"13/16	79"3/8	90"9/16	94"1/2	98"7/16				
		82"11/16	87"1/4	98"7/16						

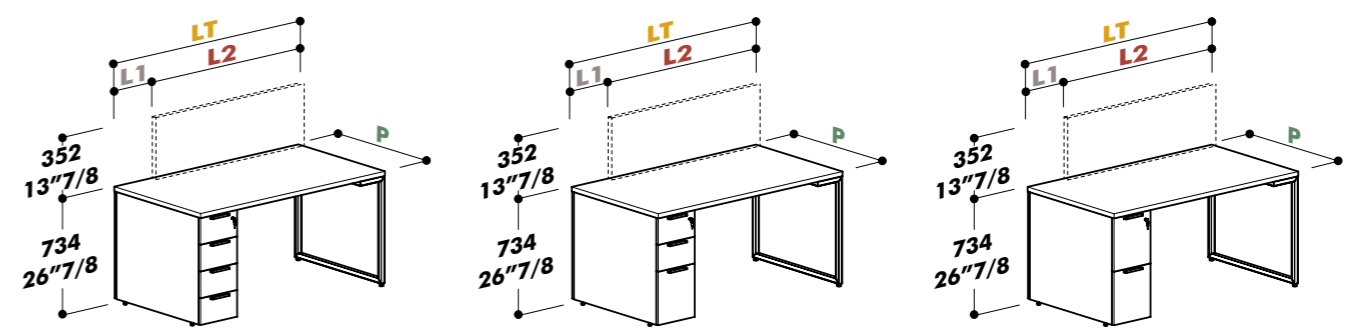

**Scrivania con cass.** desk with pedestal/bureau avec caisson/ mesa con buc

LT = L1 + L2		L1							P	
		300	416	700	800	900				
L2	1200	11"13/16	16"3/8	27"9/16	31"1/2	35"7/16			1200	47"1/4
	1400	59"1/16	63"5/8	74"13/16	78"3/4	82"11/16			1600	63"
	1600	66"15/16	71"1/2	82"11/16	86"5/8	90"9/16				
	1800	74"13/16	79"3/8	90"9/16	94"1/2	98"7/16				
		82"11/16	87"1/4	98"7/16						

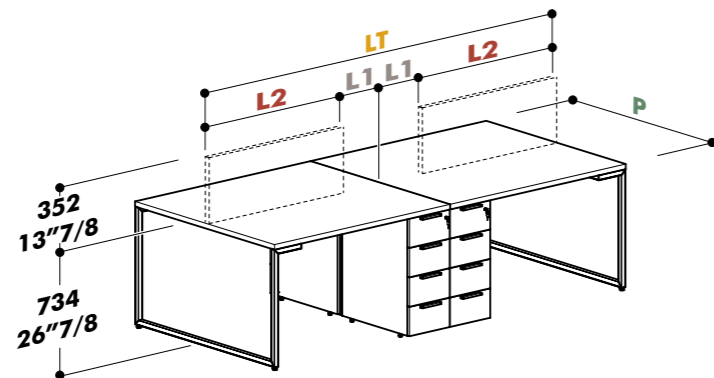

**Bench 4p. con cass** bench 4 p. with pedestal/bench 4 p. avec caisson/bench 4 p. con buc

LT = (L1 + L2) * 2		L1							P	
		300	416	700	800	900				
L2	1200	11"13/16	16"3/8	27"9/16	31"1/2	35"7/16			1200	47"1/4
	1400	118"1/8	127"1/4	149"5/8	157"1/2	165"3/8			1600	63"
	1600	133"7/8	143"	165"3/8	173"1/4	181"1/8				
	1800	149"5/8	158"3/4	181"1/8	189"	196"7/8				
		165"3/8	174"1/2	196"7/8						

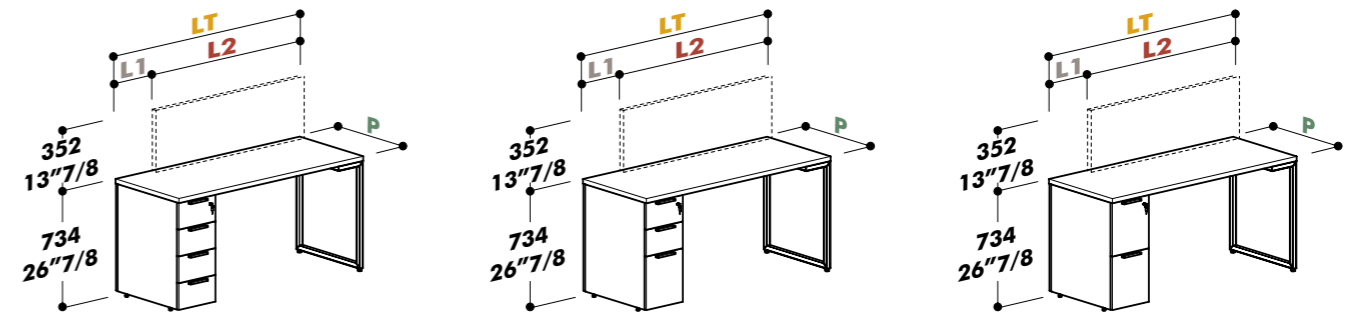

**Dattilo indipendente con cass.** freestanding return with pedestal/retour endépendant avec caisson/ala indipendente con buc

LT = L1 + L2		L1							P	
		300	416	700	800	900				
L2	1200	11"13/16	16"3/8	27"9/16	31"1/2	35"7/16			600	23"5/8
	1400	59"1/16	63"5/8	74"13/16	78"3/4	82"11/16				
	1600	66"15/16	71"1/2	82"11/16	86"5/8	90"9/16				
	1800	74"13/16	79"3/8	90"9/16	94"1/2	98"7/16				
		82"11/16	87"1/4	98"7/16						

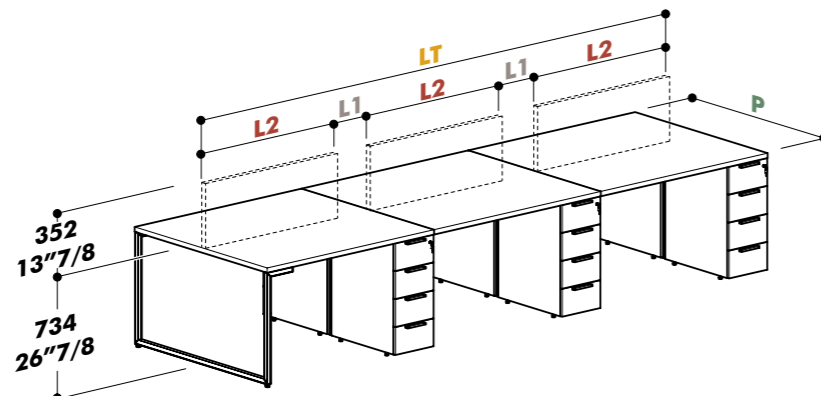

**Bench 6p. con cass.** bench 6 p. with pedestal/bench 6p. avec caisson/bench 6p. con buc

LT = (L1 + L2) * 3		L1							P	
		300	416	700	800	900				
L2	1200	11"13/16	16"3/8	27"9/16	31"1/2	35"7/16			1200	47"1/4
	1400	177"3/16	190"7/8	224"7/16	236"1/4	248"1/16			1600	63"
	1600	200"13/16	214"1/2	248"1/16	259"13/16	271"5/8				
	1800	224"7/16	238"1/8	271"5/8	283"7/16	295"1/4				
		248"1/16	261"3/4	295"1/4						

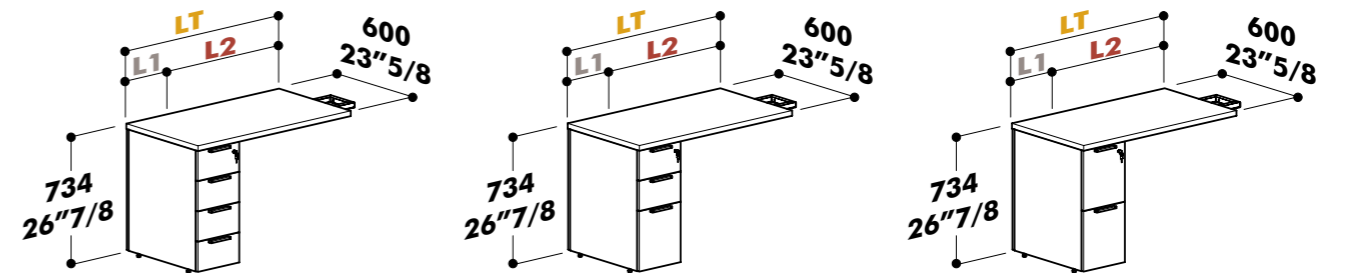

**Dattilo agganciato con cass.** hanging return with pedestal/retour accroché avec caisson/ala suspendida con buc

LT = L1 + L2		L1							P	
		300	416	700	800	900				
L2	800	11"13/16	16"3/8	27"9/16	31"1/2	35"7/16			1200	47"1/4
	1000	45"5/16	47"7/8	59"1/16	63	66"15/16			1600	63"
	1200	51"3/16	55"3/4	66"15/16	70"7/8	74"13/16			1900	82"11/16
		59"1/16	63"5/8	74"13/16	78"3/4	82"11/16				
		66"15/16	71"1/2	82"11/16	86"5/8	90"9/16				

## Tavoli riunione

meeting tables/tables de réunion/mesas de juntas

H 734 28"7/8  
1050 41"5/16

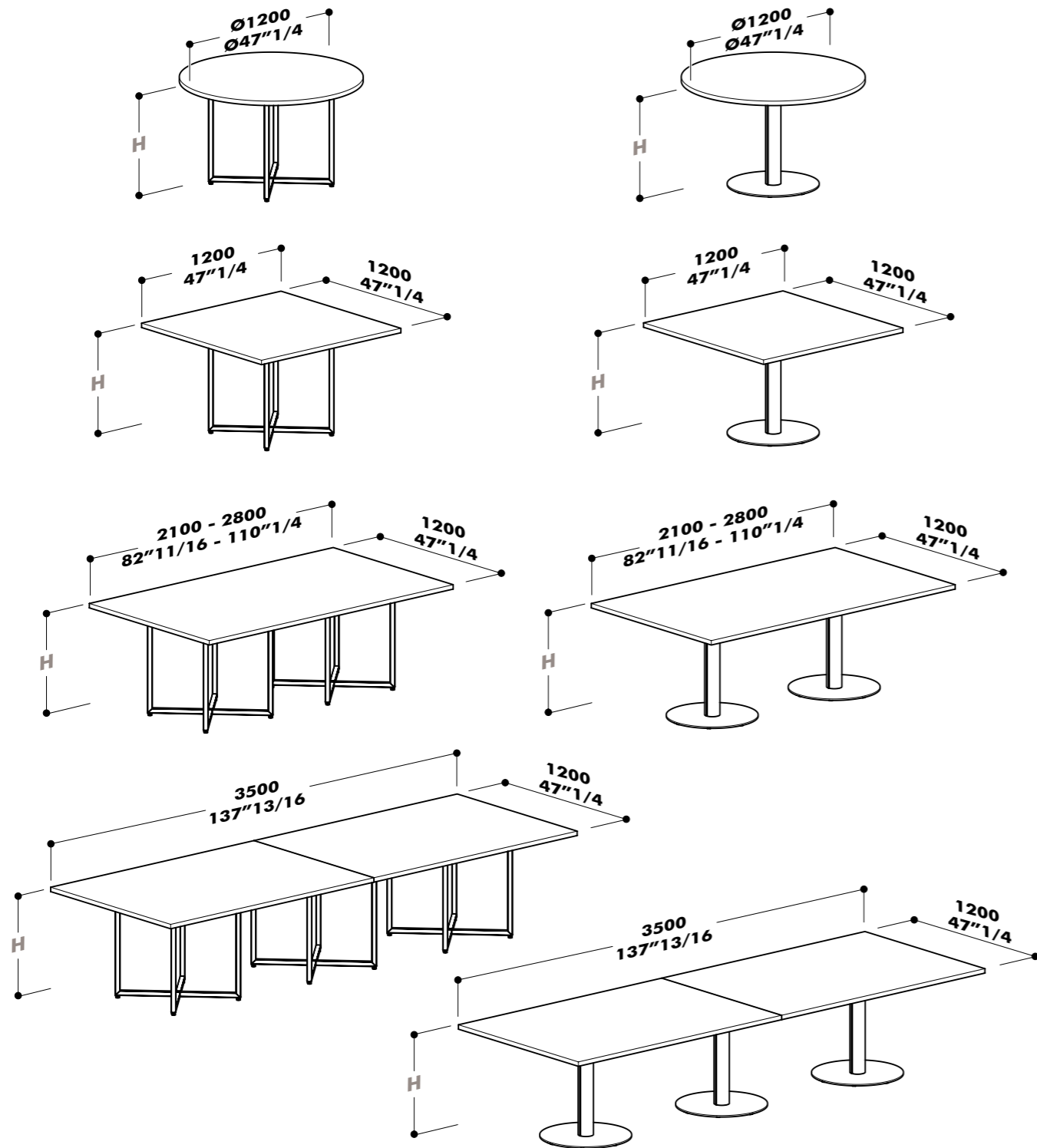

## Tavoli caffè

coffee tables/tables basses/mesitas

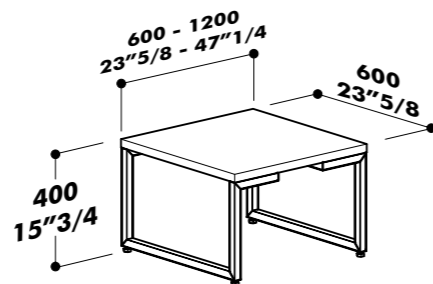

## Finiture | Finishes | Finitions | Acabados

### MEL

#### Melaminico

Melamine | Mèlaminé | Melaminico

TOP CAS MOD

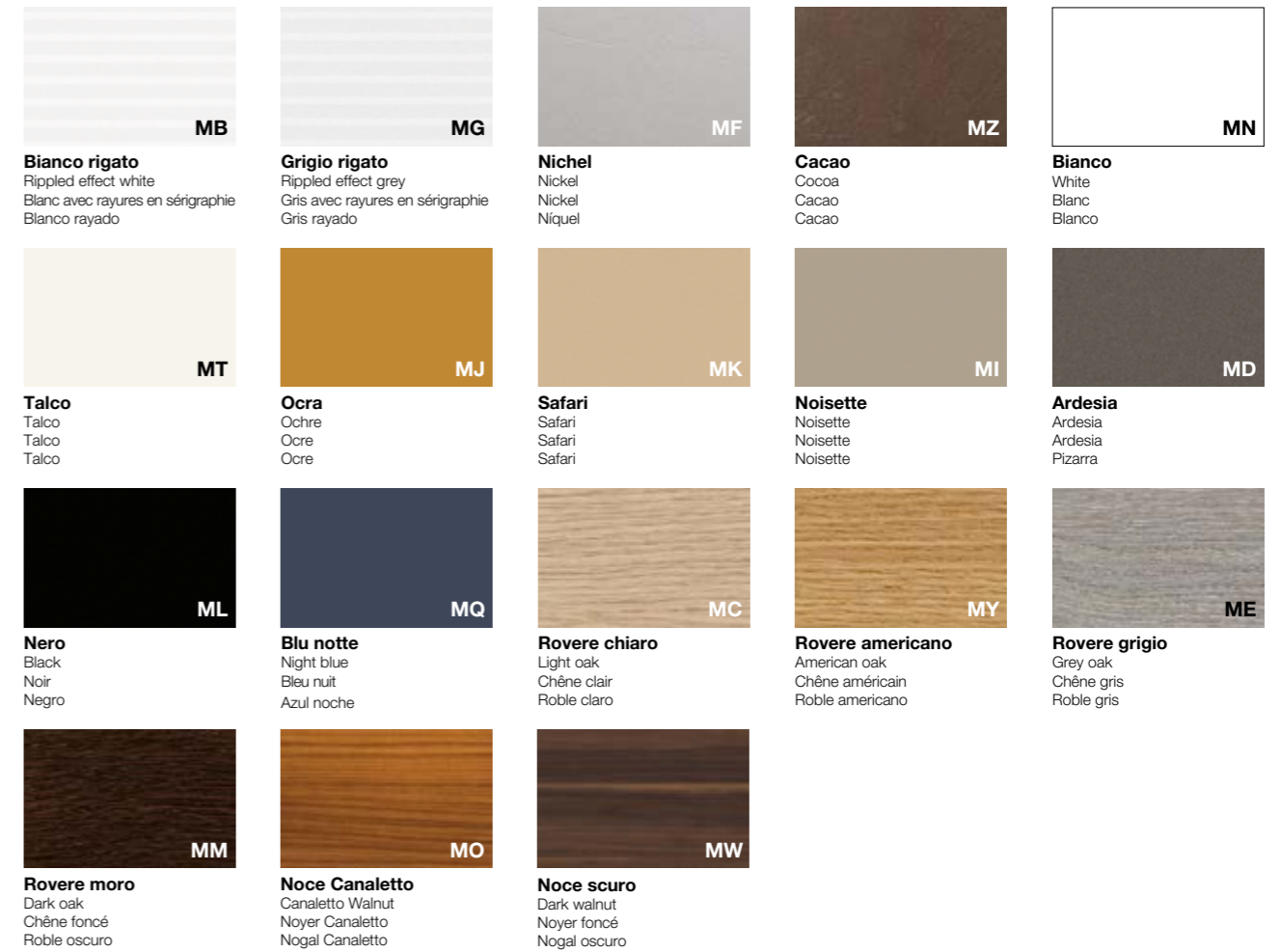

### VTR

#### Vetro

Glass | Verre | Vidrio



Trasparente  
Transparent  
Transparent  
Transparente

TOP



## CUO

### Cuoio

Leather | Cuir | Cuero

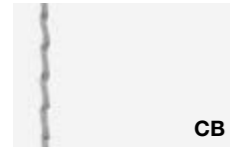

**Bianco**  
White  
Blanc  
Blanco



**Alluminio**  
Aluminium  
Aluminium  
Aluminio



**Nero**  
Black  
Noir  
Negro



**Testa di moro**  
Brown  
Tete de maure  
Marron oscuro



**Caramello**  
Caramel  
Caramel  
Caramelo



**Arancione**  
Orange  
Orange  
Naranja

TOP

## TES

### Tessuto

Fabric | Tissu | Tejido



**Beige**  
Beige  
Beige  
Beige

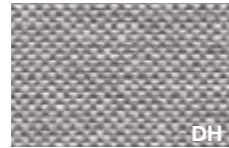

**Grigio chiaro**  
Light grey  
Gris clair  
Gris claro



**Ardesia**  
Ardesia  
Ardesia  
Pizarra



**Blu avio**  
Avio blue  
Bleu avio  
Azul avio



**Acquamarina**  
Aquamarine  
Aigue-marine  
Aguamarina

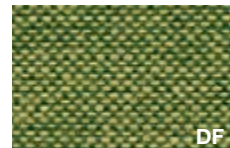

**Verde primavera**  
Spring green  
Vert printemps  
Verde primavera

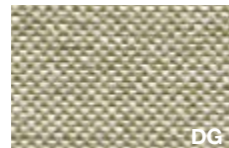

**Salvia**  
Sage  
Sauge  
Salvia



**Arancio**  
Orange  
Orange  
Naranja



**Corallo**  
Coral  
Corail  
Coral

SCR

## MTC

### Metacrilato

Acrylic | Méthacrylate | Metacrilato



**Bianco opalino**  
Opaline white  
Blanc opalin  
Blanco opaco



**Trasparente**  
Transparent  
Transparent  
Transparente



**Rosso trasparente**  
Red transparent  
Rouge transparent  
Rojo transparente



**Blu trasparente**  
Blue transparent  
Bleu transparent  
Azul transparente

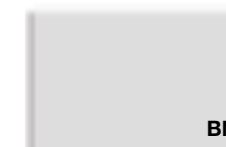

**Bianco satinato**  
Satin-finish white  
Blanc satiné  
Blanco satinado



**Grigio fumè satinato**  
Satin-finish smoky grey  
Gris satiné  
Gris satinado



**Arancione satinato**  
Satin-finish orange  
Orange satiné  
Naranja satinado



**Blu satinato**  
Satin-finish blue  
Bleu satiné  
Azul satinado



**Verde satinato**  
Satin-finish green  
Vert satiné  
Verde satinado

SCR

## EPX

### Epossidico

Epoxy | Époxy | Epoxi



**Bianco**  
White  
Blanc  
Blanco

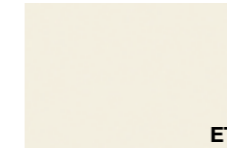

**Talco**  
Talco  
Talco  
Talco



**Grigio**  
Grey  
Gris  
Gris



**Beige Arizona**  
Arizona beige  
Beige Arizona  
Beige Arizona



**Noisette**  
Noisette  
Noisette  
Noisette



**Safari**  
Safari  
Safari  
Safari



**Rame**  
Copper  
Cuivre  
Cobre

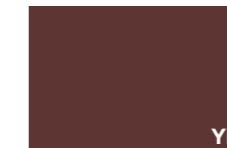

**Rosso Jaipur**  
Jaipur red  
Rouge Jaipur  
Rojo Jaipur

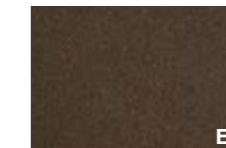

**Bronzo**  
Bronze  
Bronze  
Bronze



**Blu notte**  
Night blue  
Bleu nuit  
Azul noche



**Grigio Bromo**  
Bromo grey  
Gris Bromo  
Gris Bromo

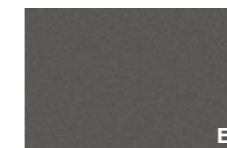

**Ardesia**  
Ardesia  
Ardesia  
Pizarra



**Verde Comodoro**  
Comodoro green  
Vert Comodoro  
Verde Comodoro



**Nero**  
Black  
Noir  
Negro

STRU

## Applicazioni finiture

Finish application | Application finitions | Aplicacion acabados



**TOP**  
Top  
Plano  
Plateau  
Sobre



**SCR**  
Screen  
Screen  
Écran  
Panel



**MOD**  
Modesty panel  
Modesty panel  
Voile de fond  
Faldón



**CAS**  
Cassettiera  
Drawer unit  
Caisson  
Buc de cajones



**STRU**  
Struttura  
Structure  
Structure  
Estructura

Le finiture contenute nella stampa sono puramente indicative e non sono di riferimento per le forniture del prodotto

Due to the printing process, finishes shown in this document are for illustration only. The finish on the final item may differ slightly from the printed illustration  
Les finitions contenues dans l'impression sont purement indicatives et ne sont pas pertinentes pour les fournitures du produit  
Los acabados contenidos en la impresión son puramente indicativos y no son de referencia para los suministros del producto

## **Ambiente e sicurezza** | Environment and safety | Environnement et sécurité | Medio ambiente y seguridad

Alea utilizza per i suoi prodotti e i suoi imballi materiali facilmente separabili e riciclabili.  
Nella produzione dei suoi manufatti, Alea si impegna ad utilizzare materiali legnosi FSC e pannelli a base di legno con certificazione CARB2. I pannelli CARB2 presentano un rilascio di formaldeide inferiore rispetto al pannello E1 comunemente utilizzato (classe E1 secondo il DM 10/10/2008).

Alea uses materials that are easy to separate and recycle for its products and packaging.  
Alea is committed to using FSC wood-based materials and CARB2-certified wood-based panels.  
CARB2 panels have a lower formaldehyde release than the commonly used E1 panel (class E1 according to DM 10/10/2008).

Alea utilise des matériaux facilement séparables et recyclables pour ses produits et ses emballages.  
Dans la production de ses produits, Alea s'engage à utiliser des matériaux en bois FSC et des panneaux à base de bois avec la certification CARB2. Les panneaux CARB2 dégagent moins de formaldéhyde que le panneau E1 couramment utilisé (classe E1 selon DM 10/10/2008).

Para sus productos y embalajes, Alea utiliza materiales fácilmente separables y reciclables.  
En la fabricación de sus productos, Alea se compromete a utilizar materiales de madera FSC y paneles de madera con certificación CARB2. Los paneles CARB2 tienen una menor liberación de formaldehído que el panel E1 comúnmente utilizado (clase E1 según DM 10/10/2008).

**concept & graphic design**  
Alea marketing + communication

**design**  
Filippon & Mirto Antonel

**art direction**  
Mirto Antonel

AF/CACB/AB



**GLOBAL HEADQUARTERS AND SHOWROOM** : Via Col de Rust, 19 - 33070 Sarone (PN) - Italia : Tel ++39 0434 777 333  
email: info@aleaoffice.com **PARIS SHOWROOM** : 176 Avenue Charles de Gaulle 92200, Neuilly-sur-Seine - France **NORTH AMERICAN**  
**HEADQUARTERS** : Midtown 2, 3449 NE 1st Avenue L-32, Miami, FL 33137 - USA : Tel ++1 305 470 1200 - email: info@alea-usa.com  
**ALEA UK OFFICE AND SHOWROOM** : 50-54 Clerkenwell Road, London EC1M 5PS - email: info@aleaoffice.com